

Up to 100A, High-precision current sensor chip that With stands surge currents up to 20KA

Description

SC840 is a new member of Senko Micro fully integrated current sensor product line, The industry's first fully integrated current detection chip that can pass 20kA/8us lightning surge test. This product with the world's first packaging technology, in 10mm*11mm*2.3mm wide-body SOP16 encapsulation on realized as low as 0.2 mΩ current lead impedance, this enables it to be applied to power systems requiring continuous operation at measurements up to 100A.

Senko Micro's SC840 series is an isolated current detection chip that uses the principle of open-loop Hall sensor detection. By introducing the current wire on the high-voltage side into the package, based on the magnetic effect of the current, the amount of iso-magnetic field generated around the wire under test is induced by the magnetic sensor of the built-in chip and converted to a treatable ethonal-voltage signal, which is amplified by the built-in high-precision ADC reading, with digital calibration technology, to remove environmental variables such as temperature, noise, hysteresis, nonlinearity, and finally the voltage value of the current under test is nearly ideal.

SC840 adopts automatic production and processing, can bring customers incomparable consistency, high quality and high reliability of module technology. Standard package design is very suitable for customers to carry out batch automatic patch production, which is the best solution for photovoltaic inverter, household appliances, charging pile.

Senko Micro is committed to the research of core chip technology, with the aim of bringing customers the best current detection solution.

Features

- 4.8 kV RMS minimum isolation voltage
- Output voltage proportional to AC or DC currents
- Lowest Current conductor impedance :0.2mΩ
- 20kA 8/20uS surge current bearing capacity
- Support Vout - Vref differential output mode
- Fixed reference reference is built in and is not affected by fluctuations in the supply voltage
- 2μs output rise time in response to step input current
- Wide operation temp. range :-40°C~125°C
- Wide range of measured current:20A~150A
- Total output error <1% @TA =25°C, <3% for full temperature range.
- Strong driving ability, support the output port to connect to the load as low as 2k
- Extremely simple peripheral circuit
- Built-in AC zero-crossing detection function
- Support wave soldering full-automatic patch and tape packaging
- It is not interfered by wire magnetic field, external magnetic field and geomagnetic field
- High PSRR
- Independent copyright of Senko Micro.

Package

Top View:



Current Path view:

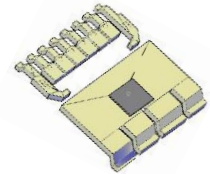

Typical Application

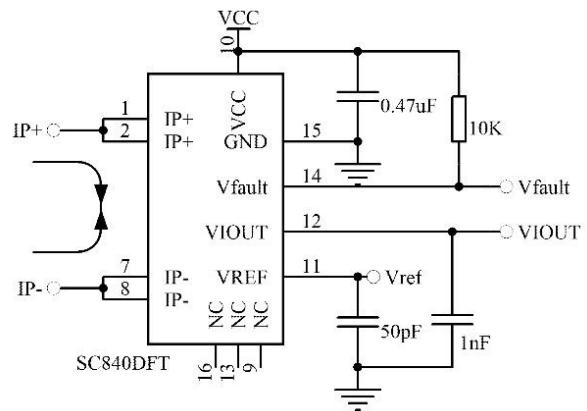

SC840 series
20kA/8us overcurrent surge, High Accuracy, Current Sensor IC



Order information

Part Number	Special Code	Temp.Range	Packing	IP(A) *3	Vout@IP=0A ¹	Sens@VCC=5V(mv/A)	
SC840DFT-20F5	D	F(-40~125°C)	T (Reel, 1000 pieces/reel)	± 20	F(2.5)	100	
SC840DFT-25F5				± 25		80	
SC840DFT-50F5				± 50		40	
SC840DFT-75F5				± 75		26.67	
SC840DET-100F5		E(-40~85°C)		± 100	20		
SC840DET-150F5				± 150	13.333		
SC840DFT-20B5		F(-40~125°C)		B(0.5Vcc)	± 20	100	
SC840DFT-25B5					± 25	80	
SC840DFT-50B5					± 50	40	
SC840DFT-75B5					± 75	26.67	
SC840DET-100B5		E(-40~85°C)		± 100	20		
SC840DFT-20I5		F(-40~125°C)		I*3 (External VREF)	± 20	100	
SC840DFT-25I5					± 25	80	
SC840DFT-30I5					±30	66	
SC840DFT-50I5-050					± 50	I=0.5V	40
SC840DFT-50I5-075					± 50	I=0.75V	40
SC840DFT-75I5-075					± 75	I=0.75V	26.67
SC840DET-100I5					E(-40~85°C)	± 100	I*3
SC840DFT-50U5		F(-40~125°C)		U(0.1Vcc)	+50	80	
SC840DFT-75U5					+75	53.33	
SC840DET-100U5	E(-40~85°C)		+100		40		

Note 1: F, B, I, U are different in the reference output when IP=0A, F is recommended by default.

F	When IP=0A, VIOUT@0A=VREF=2.5V, Zero current voltage and sensitivity is fixed
B	When IP=0A, VIOUT@0A=0.5*VCC, suitable for bidirectional current detection, Zero Current Output and sensitivity vary with VCC ratio.
I*3	When IP=0A, VIOUT@0A=VREF=External input voltage (0.5~2.5V input range). Zero Current Output and sensitivity vary with VCC ratio.
U*2,3	When IP=0A, VIOUT@0A=0.1*VCC, suitable for unidirectional current detection, Zero Current Output and sensitivity vary with VCC ratio.

Note 2: Model U, dynamic range x2 sensitivity x2; if there is any other sensitivity requirement, can connect our FAE or agent.

Note 3: Model I, must contact FAE to confirm, with the model to inform the input voltage value, to obtain the best precision parameters. E.g. SC840DFT-20I5. I=0.5 V.

Pin Configuration

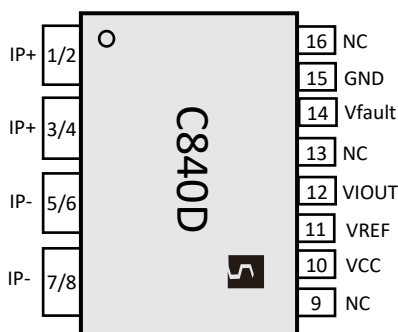

Pin Name	Pin Name	Description
1/2/3/4	IP+	The primary current is input to the positive terminal, and only 1/2 or 3/4 connection is supported
5/6/7/8	IP-	The primary current is output to the negative terminal and only 5/6 or 7/8 connection is supported
9/13/16	NC	No Connected
10	VCC	Device power supply
11	Vref	Reference terminal, support input and output. Equal to Vout@IP=0A(IP=0A)
12	VIOUT	Analog output signal. VIOUT=IP*Sens+Vref
14	Vfault	Built-in 1.3 times IP overcurrent protection output and open drain output
15	GND	Signal Ground terminal

Thermal Rise vs.Primary Current

Typical Plastic package temperature[°C] of SC840 vs Primary current [A] based on Demo Board

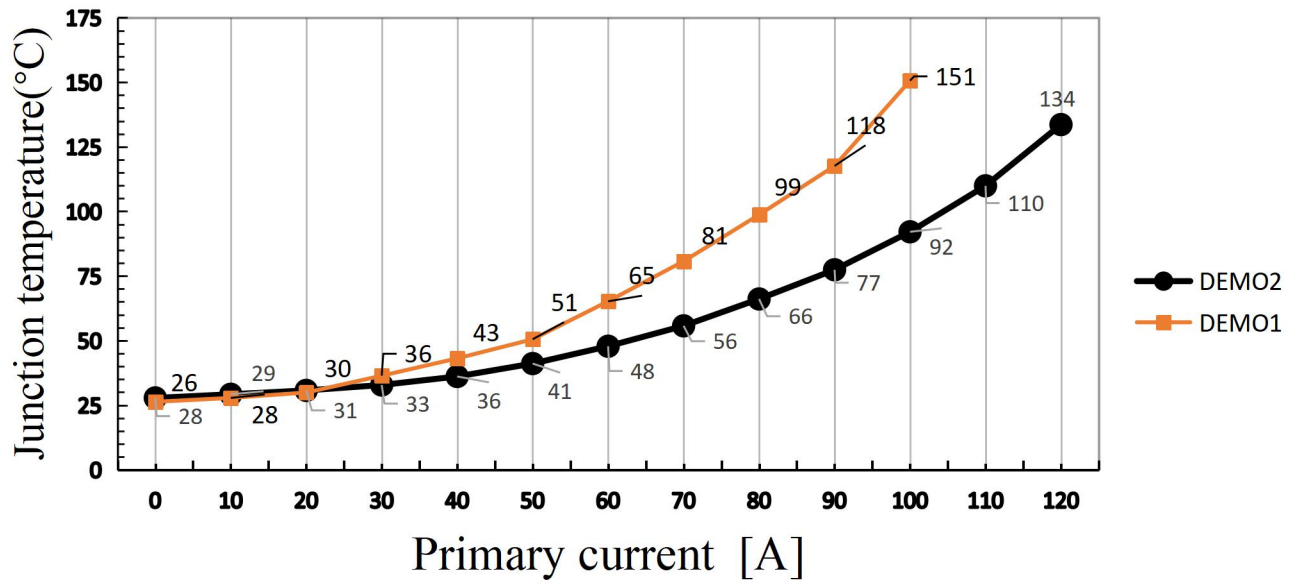

Demo Board information

Parameter	DEMO1	DEMO2	Units
Layer Number	2	2	
Copper layer thickness	2	2	Oz
Total Copper size connected to Primary pins(including all layers)	1520	4581	mm ²
Board Thickness	1.6	1.6	mm

Fuctional Block Diagram

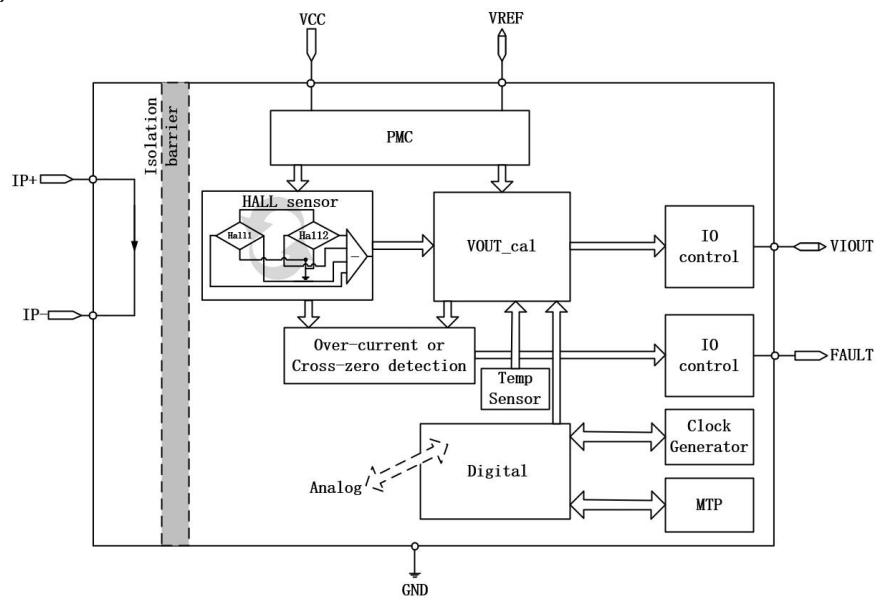

Absolute Maximum Ratings

Absolute maximum rating is the operating limit of a device, exceeding which may cause device damage. Frequent operation outside this value range may affect device reliability.

Characteristic	Symbol	Notes	Rating	Unit
Supply voltage	V _{CC}		6.0	V
Reverse Supply Voltage	V _{RCC}		-0.1	V
Output Voltage	V _{IOUT}		6.0	V
Reverse Output Voltage	V _{RIOUT}		-0.1	V
Nominal Operating Ambient Temperature	T _A	Range F	-40~125	°C
		Range E	-40~85	
Maximum Junction Temperature	T _{J(max)}		165	°C
Storage Temperature	T _{stg}		-65~170	°C
Output Current Source	I _{OUT(Source)}	Shorted Output-to-Ground Current	3.43	mA
Output Current Sink	I _{OUT(Sink)}	Shorted Output-to-VCC Current	40	mA
Vref Current Source	I _{REF(Source)}	Shorted Vref-to-Ground Current	3.47	mA
Vref Current Sink	I _{REF(Sink)}	Shorted Vref-to-VCC Current	40	mA
Overcurrent Fault Output Pin Resistance	R _{vfault}	Must not be lower than this value @ pull-up power supply =5V	2	kΩ
The Pull-up Voltage of V _{fault}	V _{CCfault}	Open-drain output, supporting independent VCC connection, but not higher than this requirement	8	V
Maximum Continuing IP Current	I _{Pmax}	Based on Senko's Demo Test Board	100	A
Transient Over Current at Ambient Temperature	I _{Pover}	Based on Senko's Demo Test Board , 1pulse , 100ms , 1% Duty Cycle	400	A
HBM mode	ESD		4	kV

Isolation Characteristics

Parameter	Symbol	Value	Unit	Comment
RMS voltage for AC insulation test,50Hz,1min	V _{ISO}	4800	V _{rms}	Agency type-tested for 60 seconds per UL60950-1
Working Voltage for Basic Isolation	V _{WVBI}	1600	V _{Peak}	Maximum working voltage according to UL60950-1
Clearance	D _{cl}	8	mm	Minimum distance through air from IP leads to signal leads
Creepage distance	D _{cr}	8	mm	Minimum distance along package body from IP leads to signal leads
Comparative trackong index	CTI	600	V	the electrical breakdown (tracking) properties of an insulating material
Maximum surge isolation voltage	V _{IOSM}	10	kV	V _{TEST} =1.3 x V _{IOTM} =13000V _{PK} ,1.2/50us waveform
Maximum Transient impulse current	I _{IOSM}	20	kA	I _{TEST} =I _{IOTM} ,t=8/20us(qualification);

Reference application Specification

Symbol	Description	Min	Typ	Max	Unit
C _{VCC}	The filter capacitor of power supply is connected between VCC and GDN	0.1	0.47	----	uF
C _{VIOUT}	The filter capacitor of Output is connected between Vout and GND	NC	1	1.5	nF
C _{VREF}	The filter capacitor of Output is connected between Vref and GND	NC	50	100	pF
R _{Vfault}	The pull-up resistance is connected between V _{fault} and VCC	2	10	100	kΩ

SC840 series
20kA/8us overcurrent surge, High Accuracy, Current Sensor IC



Common Electrical Characteristics

Note: Over full range of $T_A=25^{\circ}\text{C}$, $C_{\text{Bypass}}=0.47\mu\text{F}$, $C_{\text{Load}}=1.0\text{nF}$, $V_{\text{CC}}=5\text{V}$, sensitivity=40mv/A

Characteristic	Symbol	Test Conditions	Min	Typ	Max	Unit
Supply Voltage	V_{CC}	Operating	4.5	5	5.5	V
Supply Current	I_{CC}	$V_{\text{CC}} = 4.5\sim 5.5\text{V}$, output open		20		mA
Output Capacitance Load	C_{L}	VIOUT to GND		1	1.5	nF
Output Resistive Load	R_{L}	VIOUT to GND	2.2			k Ω
VREF Capacitance Load	C_{LREF}	VREF to GND		50	100	pF
VREF Resistive Load	R_{LREF}	VREF to GND	2.2			k Ω
Hall coupling factor	CF	$T_A = 25^{\circ}\text{C}$		0.83		G/A
Anti-external magnetic interference suppression ratio	CMFR	The external interference magnetic field perpendicular to the chip surface		-43		dB
Primary Conductor Resistance	R_{PRIMARY}	$T_A = 25^{\circ}\text{C}$		0.21		m Ω
Temperature Coefficient of Primary Conductor Resistance	TC_R	$T_A=-40\sim 125^{\circ}\text{C}$		3361		ppm/ $^{\circ}\text{C}$
Hysteresis Voltage	V_{hys}	V_{Iout} (IP to +40A then return to 0A)- V_{Iout} (IP to -40A, then return to 0A)		1		mV
Rise time	t_r	IP=50A(50A/us)		2		μs
Propagation Delay	t_{pd}	IP=50A(50A/us)		1.2		μs
Response Time	t_{response}	IP=50A(50A/us)		1.5		μs
Bandwidth	f	Small-Signal-3 dB,		180		kHz
Noise Density	I_{ND}	$T_A = 25^{\circ}\text{C}$, $C_{\text{L}}=1\text{nF}$		1545		$\mu\text{A}(\text{rms})/\sqrt{\text{Hz}}$
Noise	I_{N}	NC		0.46		mA(rms)
	I_{N}	RC filter BW=10KHz		0.12		mA(rms)
	I_{N}	RC filter BW=1KHz		0.05		mA(rms)
Nonlinearity	E_{LIN}	-50A<IP<50A			1	%
Bidirectional Quiescent Output(suitable for product with suffix B5)	S_{coef}	$V_{\text{CC}}=4.5\sim 5.5\text{V}$, $S_{\text{coef}}=\text{Sens}(V_{\text{CC}})/\text{Sens}(5\text{V})$		$V_{\text{CC}}/5$		
Sensitivity under fixed zero voltage(suitable for product with suffix F5)		$V_{\text{CC}}=5\text{V}$, Type selection is xxF5		$2000/I_{\text{PR}}$		mv/A
$V_{\text{out}}@0\text{A}$ under fixed zero voltage(suitable for product with suffix F5)		$V_{\text{CC}}=5\text{V}$, Type selection is xxF5		2.5		V
External Vref Voltage Range		$V_{\text{CC}}=5.0\text{V}$, Type selection is xxI5	0.5		2.5	V
VIOUT LinearRail to Rail Output Range	$V_{\text{rail-rail}}$	$R_{\text{L}}=4.7\text{k}\Omega$	10		90	%VCC
Power-On Time	t_{PO}	Output reaches steady state level, $T_J = 25^{\circ}\text{C}$		100	200	μs
PSRR of $V_{\text{OUT}}@0\text{A}$ (suitable for product with suffix F5)	PSRR _Q			40		dB
PSRR of Sensitivity(suitable for product with suffix F5)	PSRR _S			26		dB

SC840 series
20kA/8us overcurrent surge, High Accuracy, Current Sensor IC



SC840DFT-20B5 Individual Performance Characteristics

Note: Over full range of $T_A = -40 \sim 125^\circ\text{C}$, $C_{\text{Bypass}} = 0.47\mu\text{F}$, $C_{\text{Load}} = 1.0\text{nF}$, $V_{\text{CC}} = 5\text{V}$, unless otherwise specified.

Parameter	Symbol	Test Conditions	Min	Typ ^[1]	Max	Unit
NOMINAL PERFORMANCE						
Current-Sensing Range	I_{PR}		-20		20	A
Zero-Current Output Voltage	V_{OQ}	$I_{\text{P}} = 0\text{A}$		0.5V _{CC}		V
VREF Output Voltage	V_{REF}	Independent of the IP input current		0.5V _{CC}		V
Differential Output Offset Voltage	$V_{\text{OQ}} - V_{\text{REF}}$	$I_{\text{P}} = 0\text{A}$	-15	0	15	mV
Sensitivity	Sens	$-20\text{A} < I_{\text{P}} < 20\text{A}$		100 * S _{coef}		mV/A
ACCURACY PERFORMANCE						
Sensitivity Error	E_{SENS}	$I_{\text{P}} = \pm 20\text{A}$, $T_A = 25^\circ\text{C}$		± 1		%
		$I_{\text{P}} = \pm 20\text{A}$, $T_A = 25 \sim 125^\circ\text{C}$		± 2		%
		$I_{\text{P}} = \pm 20\text{A}$, $T_A = -40 \sim 25^\circ\text{C}$		± 3		%
Offset Voltage	V_{OE}	$I_{\text{P}} = 0\text{A}$, $T_A = 25^\circ\text{C}$		± 10		mV
		$I_{\text{P}} = 0\text{A}$, $T_A = 25 \sim 125^\circ\text{C}$		± 35		mV
		$I_{\text{P}} = 0\text{A}$, $T_A = -40 \sim 25^\circ\text{C}$		± 30		mV
Differential Output Error	$E_{(V_{\text{OQ}} - V_{\text{REF}})}$	$I_{\text{P}} = 0\text{A}$, $T_A = 25^\circ\text{C}$		± 10		mV
		$I_{\text{P}} = 0\text{A}$, $T_A = 25 \sim 125^\circ\text{C}$		± 25		mV
		$I_{\text{P}} = 0\text{A}$, $T_A = -40 \sim 25^\circ\text{C}$		± 20		mV
Nonlinearity	E_{LIN}	Measured using full-scale and half-scale I_{P}			1	%
TOTAL OUTPUT ERROR COMPONENTS: $E_{\text{TOT}} = E_{\text{SENS}} + V_{\text{OE}} / (\text{Sens} \times I_{\text{P}})$						
Total Output Error	E_{TOT}	$I_{\text{P}} = \pm 20\text{A}$, $T_A = 25^\circ\text{C}$		± 1.0		%
		$I_{\text{P}} = \pm 20\text{A}$, $T_A = 25^\circ\text{C} \sim 125^\circ\text{C}$		± 3		%
		$I_{\text{P}} = \pm 20\text{A}$, $T_A = -40^\circ\text{C} \sim 25^\circ\text{C}$		± 3.5		%
Over Life Time drift Error	E_{olt}			± 1		%

[1] The typical value is +/-1 sigma, and 68.27% of products fall within this range; The maximum/minimum value is +/-3 sigma value, and 99.73% of products fall within this range

SC840DFT-20F5 Individual Performance Characteristics

Note: Over full range of $T_A = -40 \sim 125^\circ\text{C}$, $C_{\text{Bypass}} = 0.47\mu\text{F}$, $C_{\text{Load}} = 1\text{nF}$, $V_{\text{CC}} = 5\text{V}$, unless otherwise specified.

Parameter	Symbol	Test Conditions	Min	Typ ^[1]	Max	Unit
NOMINAL PERFORMANCE						
Current-Sensing Range	I_{PR}		-20		20	A
Zero-Current Output Voltage	V_{OQ}	$I_{\text{P}} = 0\text{A}$		2.5		V
VREF Output Voltage	V_{REF}	Independent of the IP input current		2.5		V
Differential Output Offset Voltage	$V_{\text{OQ}} - V_{\text{REF}}$	$I_{\text{P}} = 0\text{A}$	-15	0	15	mV
Sensitivity	Sens	$-20\text{A} < I_{\text{P}} < 20\text{A}$		100		mV/A
ACCURACY PERFORMANCE						
Sensitivity Error	E_{SENS}	$I_{\text{P}} = \pm 20\text{A}$, $T_A = 25^\circ\text{C}$		± 1		%
		$I_{\text{P}} = \pm 20\text{A}$, $T_A = 25 \sim 125^\circ\text{C}$		± 2		%
		$I_{\text{P}} = \pm 20\text{A}$, $T_A = -40 \sim 25^\circ\text{C}$		± 3		%
Offset Voltage	V_{OE}	$I_{\text{P}} = 0\text{A}$, $T_A = 25^\circ\text{C}$		± 10		mV
		$I_{\text{P}} = 0\text{A}$, $T_A = 25 \sim 125^\circ\text{C}$		± 35		mV
		$I_{\text{P}} = 0\text{A}$, $T_A = -40 \sim 25^\circ\text{C}$		± 30		mV
Differential Output Error	$E_{(V_{\text{OQ}} - V_{\text{REF}})}$	$I_{\text{P}} = 0\text{A}$, $T_A = 25^\circ\text{C}$		± 10		mV
		$I_{\text{P}} = 0\text{A}$, $T_A = 25 \sim 125^\circ\text{C}$		± 25		mV
		$I_{\text{P}} = 0\text{A}$, $T_A = -40 \sim 25^\circ\text{C}$		± 20		mV
Nonlinearity	E_{LIN}	Measured using full-scale and half-scale I_{P}			1	%
TOTAL OUTPUT ERROR COMPONENTS: $E_{\text{TOT}} = E_{\text{SENS}} + V_{\text{OE}} / (\text{Sens} \times I_{\text{P}})$						
Total Output Error	E_{TOT}	$I_{\text{P}} = \pm 20\text{A}$, $T_A = 25^\circ\text{C}$		± 1.0		%
		$I_{\text{P}} = \pm 20\text{A}$, $T_A = 25^\circ\text{C} \sim 125^\circ\text{C}$		± 3		%
		$I_{\text{P}} = \pm 20\text{A}$, $T_A = -40^\circ\text{C} \sim 25^\circ\text{C}$		± 3.5		%
Over Life Time drift Error	E_{olt}			± 1		%

[1] The typical value is +/-1 sigma, and 68.27% of products fall within this range; The maximum/minimum value is +/-3 sigma value, and 99.73% of products fall within this range

SC840 series
20kA/8us overcurrent surge, High Accuracy, Current Sensor IC



SC840DFT-25B5 Individual Performance Characteristics

Note: Over full range of TA=-40~125°C, C_{Bypass}=0.47uF, C_{Load}=1nF, V_{CC}=5V, unless otherwise specified.

Parameter	Symbol	Test Conditions	Min	Typ ^[1]	Max	Unit
NOMINAL PERFORMANCE						
Current-Sensing Range	I _{PR}		-25		25	A
Zero-Current Output Voltage	V _{oq}	IP=0A		0.5V _{CC}		V
VREF Output Voltage	V _{ref}	Independent of the IP input current		0.5V _{CC}		V
Differential Output Offset Voltage	V _{oq} -V _{REF}	IP=0A	-15	0	15	mV
Sensitivity	Sens	-25A<IP<25A		80* S _{coef}		mV/A
ACCURACY PERFORMANCE						
Sensitivity Error	E _{SENS}	I _P = ±25 A, T _A = 25°C		± 1		%
		I _P = ±25 A, T _A = 25~125°C		± 2		%
		I _P = ±25 A, T _A = - 40~25°C		± 3		%
Offset Voltage	V _{OE}	I _P =0A, T _A = 25°C		± 10		mV
		I _P =0A, T _A = 25~125°C		± 35		mV
		I _P =0A, T _A = - 40~25°C		± 30		mV
Differential Output Error	E _(V_{oq}-V_{REF})	I _P =0A, T _A = 25°C		± 10		mV
		I _P =0A, T _A = 25~125°C		± 25		mV
		I _P =0A, T _A = - 40~25°C		± 20		mV
Nonlinearity	E _{LIN}	Measured using full-scale and half-scale I _P		± 0.5	1	%
TOTAL OUTPUT ERROR COMPONENTS: E_{TOT} = E_{SENS} + V_{OE} / (Sens × I_P)						
Total Output Error	E _{TOT}	I _P = ±25 A, T _A =25°C		± 1.0		%
		I _P = ±25 A, T _A =25°C~125°C		± 3		%
		I _P = ±25 A, T _A = - 40°C ~ 25°C		± 3.5		%
Over Life Time drift Error	E _{olt}			±1		%

[1] The typical value is +/-1 sigma, and 68.27% of products fall within this range; The maximum/minimum value is +/-3 sigma value, and 99.73% of products fall within this range

SC840DFT-25F5 Individual Performance Characteristics

Note: Over full range of TA=-40~125°C, C_{Bypass}=0.47uF, C_{Load}=1nF, V_{CC}=5V, unless otherwise specified.

Parameter	Symbol	Test Conditions	Min	Typ ^[1]	Max	Unit
NOMINAL PERFORMANCE						
Current-Sensing Range	I _{PR}		-25		25	A
Zero-Current Output Voltage	V _{oq}	IP=0A		2.5		V
VREF Output Voltage	V _{ref}	Independent of the IP input current		2.5		V
Differential Output Offset Voltage	V _{oq} -V _{REF}	IP=0A	-15	0	15	mV
Sensitivity	Sens	-25A<IP<25A		80		mV/A
ACCURACY PERFORMANCE						
Sensitivity Error	E _{SENS}	I _P = ±25 A, T _A = 25°C		± 1		%
		I _P = ±25 A, T _A = 25~125°C		± 2		%
		I _P = ±25 A, T _A = - 40~25°C		± 3		%
Offset Voltage	V _{OE}	I _P =0A, T _A = 25°C		± 10		mV
		I _P =0A, T _A = 25~125°C		± 35		mV
		I _P =0A, T _A = - 40~25°C		± 30		mV
Differential Output Error	E _(V_{oq}-V_{REF})	I _P =0A, T _A = 25°C		± 10		mV
		I _P =0A, T _A = 25~125°C		± 25		mV
		I _P =0A, T _A = - 40~25°C		± 20		mV
Nonlinearity	E _{LIN}	Measured using full-scale and half-scale I _P		± 0.5	1	%
TOTAL OUTPUT ERROR COMPONENTS: E_{TOT} = E_{SENS} + V_{OE} / (Sens × I_P)						
Total Output Error	E _{TOT}	I _P = ±25 A, T _A =25°C		± 1.0		%
		I _P = ±25 A, T _A =25°C~125°C		± 3		%
		I _P = ±25 A, T _A = - 40°C ~ 25°C		± 3.5		%
Over Life Time drift Error	E _{olt}			±1		%

[1] The typical value is +/-1 sigma, and 68.27% of products fall within this range; The maximum/minimum value is +/-3 sigma value, and 99.73% of products fall within this range

SC840 series
20kA/8us overcurrent surge, High Accuracy, Current Sensor IC



SC840DFT-50B5 Individual Performance Characteristics

Note: Over full range of TA=-40~125°C, C_{Bypass}=0.47uF, C_{Load}=1nF, V_{CC}=5V, unless otherwise specified.

Parameter	Symbol	Test Conditions	Min	Typ ^[1]	Max	Unit
NOMINAL PERFORMANCE						
Current-Sensing Range	I _{PR}		-50		50	A
Zero-Current Output Voltage	V _{oq}	I _P =0A		0.5V _{CC}		V
VREF Output Voltage	V _{ref}	Independent of the IP input current		0.5V _{CC}		V
Differential Output Offset Voltage	V _{oq} -V _{REF}	I _P =0A	-15	0	15	mV
Sensitivity	Sens	-50A<I _P <50A		40* S _{coef}		mV/A
ACCURACY PERFORMANCE						
Sensitivity Error	E _{SENS}	I _P = ±50 A, T _A = 25°C		± 1		%
		I _P = ±50 A, T _A = 25~125°C		± 2		%
		I _P = ±50 A, T _A = - 40~25°C		± 3		%
Offset Voltage	V _{OE}	I _P =0A, T _A = 25°C		± 10		mV
		I _P =0A, T _A = 25~125°C		± 38		mV
		I _P =0A, T _A = - 40~25°C		± 35		mV
Differential Output Error	E _(V_{oq}-V_{REF})	I _P =0A, T _A = 25°C		± 10		mV
		I _P =0A, T _A = 25~125°C		± 25		mV
		I _P =0A, T _A = - 40~25°C		± 20		mV
Nonlinearity	E _{LIN}	Measured using full-scale and half-scale I _P		± 0.5	1	%
TOTAL OUTPUT ERROR COMPONENTS: E_{TOT} = E_{SENS} + V_{OE} / (Sens × I_P)						
Total Output Error	E _{TOT}	I _P = ±50 A, T _A =25°C		± 1		%
		I _P = ±50 A, T _A =25°C~125°C		± 3		%
		I _P = ±50 A, T _A = - 40°C ~ 25°C		± 3.5		%
Over Life Time drift Error	E _{olt}			±1		%

[1] The typical value is +/-1 sigma, and 68.27% of products fall within this range; The maximum/minimum value is +/-3 sigma value, and 99.73% of products fall within this range

SC840DFT-50F5 Individual Performance Characteristics

Note: Over full range of TA=-40~125°C, C_{Bypass}=0.47uF, C_{Load}=1nF, V_{CC}=5V, unless otherwise specified.

Parameter	Symbol	Test Conditions	Min	Typ ^[1]	Max	Unit
NOMINAL PERFORMANCE						
Current-Sensing Range	I _{PR}		-50		50	A
Zero-Current Output Voltage	V _{oq}	I _P =0A	2.495	2.5	2.505	V
VREF Output Voltage	V _{ref}	Independent of the IP input current	2.495	2.5	2.505	V
Differential Output Offset Voltage	V _{oq} -V _{REF}	I _P =0A	-5	0	5	mV
Sensitivity	Sens	-50A<I _P <50A	39.8	40	40.2	mV/A
ACCURACY PERFORMANCE						
Sensitivity Error	E _{SENS}	I _P = ±50 A, T _A = 25°C		± 1		%
		I _P = ±50A, T _A = 25~125°C		± 2		%
		I _P = ±50 A, T _A = - 40~25°C		± 2		%
Offset Voltage	V _{OE}	I _P =0A, T _A = 25°C		± 5		mV
		I _P =0A, T _A = 25~125°C		± 38		mV
		I _P =0A, T _A = - 40~25°C		± 25		mV
Differential Output Error	E _(V_{oq}-V_{REF})	I _P =0A, T _A = 25°C		± 5		mV
		I _P =0A, T _A = 25~125°C		± 30		mV
		I _P =0A, T _A = - 40~25°C		± 20		mV
Nonlinearity	E _{LIN}	Measured using full-scale and half-scale I _P		± 0.5	1	%
TOTAL OUTPUT ERROR COMPONENTS: E_{TOT} = E_{SENS} + V_{OE} / (Sens × I_P)						
Total Output Error	E _{TOT}	I _P = ±50 A, T _A =25°C		± 1		%
		I _P = ±50 A, T _A =25°C~125°C		± 3		%
		I _P = ±50 A, T _A = - 40°C ~ 25°C		± 2.8		%
Over Life Time drift Error	E _{olt}			±1		%

[1] The typical value is +/-1 sigma, and 68.27% of products fall within this range; The maximum/minimum value is +/-3 sigma value, and 99.73% of products fall within this range

SC840 series
20kA/8us overcurrent surge, High Accuracy, Current Sensor IC



SC840DFT-50I5 Individual Performance Characteristics

Note: Over full range of TA=-40~125°C, C_{Bypass}=0.47uF, C_{Load}=1nF, V_{CC}=5V, unless otherwise specified.

Parameter	Symbol	Test Conditions	Min	Typ ^[1]	Max	Unit
NOMINAL PERFORMANCE						
Current-Sensing Range ^[2]	I _{PR}	Default one-way detection, Calculation formula of negative current range: MinIPR=(0.5-VREF_IN)/Sens			50	A
Zero-Current Output Voltage	Voq	IP=0A		=Vref		V
VREF Output Voltage	Vref	Independent of the IP input current		Pace with input		V
Sensitivity	Sens	0A<IP<50A	39.8	40	40.2	mV/A
ACCURACY PERFORMANCE						
Sensitivity Error	E _{SENS}	I _P = 50 A, T _A = 25°C	-1	± 0.5	1	%
		I _P = 50 A, T _A = 25~125°C	-3.77	± 1.2	3.77	%
		I _P = 50 A, T _A = -40~25°C	-3.22	± 1.2	3.22	%
Offset Voltage	V _{OE}	I _P =0A, T _A = 25°C	-16	± 5	16	mV
		I _P =0A, T _A = 25~125°C	-32	± 10	32	mV
		I _P =0A, T _A = -40~25°C	-28	± 10	28	mV
Nonlinearity	E _{LIN}	Measured using full-scale and half-scale I _P		± 0.5	1.5	%
TOTAL OUTPUT ERROR COMPONENTS: E_{TOT} = E_{SENS} + V_{OE} / (Sens × I_P)						
Total Output Error	E _{TOT}	I _P = 50 A, T _A =25°C	-1.71	± 1	1.71	%
		I _P = 50 A, T _A =25°C~125°C	-3.99	± 1.18	3.99	%
		I _P = 50A, T _A = -40°C~25°C	-3.66	± 1.21	3.66	%
Over Life Time drift Error	E _{olt}			±1		%

[1] The typical value is +/-1 sigma, and 68.27% of products fall within this range; The maximum/minimum value is +/-3 sigma value, and 99.73% of products fall within this range

[2]Current measurement range: the minimum viout linear output voltage is 0.5V, that is, the negative current detection range is judged according to the external VREF input voltage.

SC840DFT-75B5 Individual Performance Characteristics

Note: Over full range of TA=-40~125°C, C_{Bypass}=0.47uF, C_{Load}=1nF, V_{CC}=5V, unless otherwise specified.

Parameter	Symbol	Test Conditions	Min	Typ ^[1]	Max	Unit
NOMINAL PERFORMANCE						
Current-Sensing Range	I _{PR}		-75		75	A
Zero-Current Output Voltage	Voq	IP=0A		0.5Vcc		V
VREF Output Voltage	Vref	Independent of the IP input current		0.5Vcc		V
Differential Output Offset Voltage	Voq-VREF	IP=0A	-5	0	5	mV
Sensitivity	Sens	-75A<IP<75A		26.67* S _{coef}		mV/A
ACCURACY PERFORMANCE						
Sensitivity Error	E _{SENS}	I _P = ±75 A, T _A = 25°C		± 1		%
		I _P = ±75 A, T _A = 25~125°C		± 2		%
		I _P = ±75 A, T _A = - 40~25°C		± 3		%
Offset Voltage	V _{OE}	I _P =0A, T _A = 25°C		± 10		mV
		I _P =0A, T _A = 25~125°C		± 35		mV
		I _P =0A, T _A = - 40~25°C		± 30		mV
Differential Output Error	E _(Voq-VREF)	I _P =0A, T _A = 25°C		± 10		mV
		I _P =0A, T _A = 25~125°C		± 25		mV
		I _P =0A, T _A = - 40~25°C		± 20		mV
Nonlinearity	E _{LIN}	Measured using full-scale and half-scale I _P		± 0.5	1	%
TOTAL OUTPUT ERROR COMPONENTS: E_{TOT} = E_{SENS} + V_{OE} / (Sens × I_P)						
Total Output Error	E _{TOT}	I _P = ±75 A, T _A =25°C		± 1		%
		I _P = ±75 A, T _A =25°C~125°C		± 3		%
		I _P = ±75A, T _A = - 40°C ~ 25°C		± 2.8		%
Over Life Time drift Error	E _{olt}			±1		%

[1] The typical value is +/-1 sigma, and 68.27% of products fall within this range; The maximum/minimum value is +/-3 sigma value, and 99.73% of products fall within this range

SC840 series

20kA/8us overcurrent surge, High Accuracy, Current Sensor IC



SC840DFT-75F5 Individual Performance Characteristics

Note: Over full range of TA=-40~125°C, C_{Bypass}=0.47uF, C_{Load}=1nF, V_{CC}=5V, unless otherwise specified.

Parameter	Symbol	Test Conditions	Min	Typ ^[1]	Max	Unit
NOMINAL PERFORMANCE						
Current-Sensing Range	I _{PR}		-75		75	A
Zero-Current Output Voltage	V _{oq}	IP=0A		2.5		V
VREF Output Voltage	V _{ref}	Independent of the IP input current		2.5		V
Differential Output Offset Voltage	V _{oq} -V _{REF}	IP=0A	-5	0	5	mV
Sensitivity	Sens	-75A<IP<75A		26.67		mV/A
ACCURACY PERFORMANCE						
Sensitivity Error	E _{SENS}	I _p = ±75 A, T _A = 25°C		± 1		%
		I _p = ±75 A, T _A = 25~125°C		± 2		%
		I _p = ±75 A, T _A = - 40~25°C		± 3		%
Offset Voltage	V _{OE}	I _p =0A, T _A = 25°C		± 10		mV
		I _p =0A, T _A = 25~125°C		± 35		mV
		I _p =0A, T _A = - 40~25°C		± 30		mV
Differential Output Error	E _(V_{oq}-V_{REF})	I _p =0A, T _A = 25°C		± 10		mV
		I _p =0A, T _A = 25~125°C		± 25		mV
		I _p =0A, T _A = - 40~25°C		± 20		mV
Nonlinearity	E _{LIN}	Measured using full-scale and half-scale I _p		± 0.5	1	%
TOTAL OUTPUT ERROR COMPONENTS: E_{TOT} = E_{SENS} + V_{OE} / (Sens × I_p)						
Total Output Error	E _{TOT}	I _p = ±75A, T _A =25°C		± 1		%
		I _p = ±75 A, T _A =25°C~125°C		± 3		%
		I _p = ±75A, T _A = - 40°C ~ 25°C		± 2.8		%
Over Life Time drift Error	E _{olt}			±1		%

[1] The typical value is +/-1 sigma, and 68.27% of products fall within this range; The maximum/minimum value is +/-3 sigma value, and 99.73% of products fall within this range

SC840DFT-75I5-075 Individual Performance Characteristics

Note: Over full range of TA=-40~125°C, C_{Bypass}=0.47uF, C_{Load}=1nF, V_{CC}=5V, unless otherwise specified.

Parameter	Symbol	Test Conditions	Min	Typ ^[1]	Max	Unit
NOMINAL PERFORMANCE						
Current-Sensing Range ^[2]	I _{PR}	Default one-way detection, Calculation formula of negative current range: MinIPR=(0.5-VREF_IN)/Sens			75	A
Zero-Current Output Voltage	V _{oq}	IP=0A		=V _{ref}		V
VREF Output Voltage	V _{ref}	Independent of the IP input current		0.75		V
Sensitivity	Sens	0A<IP<75A	26.40	26.67	26.94	mV/A
ACCURACY PERFORMANCE						
Sensitivity Error	E _{SENS}	I _p = 75 A, T _A = 25°C	-1	± 0.5	1	%
		I _p = 75 A, T _A = 25~125°C	-3.5	± 2	3.5	%
		I _p = 75 A, T _A = -40~25°C	-3.1	± 2.1	3.1	%
Offset Voltage	V _{OE}	I _p =0A, T _A = 25°C	-12	± 6	12	mV
		I _p =0A, T _A = 25~125°C	-43	± 20	43	mV
		I _p =0A, T _A = -40~25°C	-32	± 12	32	mV
Nonlinearity	E _{LIN}	Measured using full-scale and half-scale I _p		± 0.5	1	%
TOTAL OUTPUT ERROR COMPONENTS: E_{TOT} = E_{SENS} + V_{OE} / (Sens × I_p)						
Total Output Error	E _{TOT}	I _p = 75 A, T _A =25°C	-1.5	±0.8	1.5	%
		I _p = 75 A, T _A =25°C~125°C	-3.9	±2	3.9	%
		I _p = 75 A, T _A = -40°C~25°C	-3.5	± 1.8	3.5	%
Over Life Time drift Error	E _{olt}			±1		%

[1] The typical value is +/-1 sigma, and 68.27% of products fall within this range; The maximum/minimum value is +/-3 sigma value, and 99.73% of products fall within this range

[2] Current measurement range: the minimum viout linear output voltage is 0.5V, that is, the negative current detection range is judged according to the external VREF input voltage.

SC840 series
20kA/8us overcurrent surge, High Accuracy, Current Sensor IC



SC840DET-100B5 Individual Performance Characteristics

Note: Over full range of TA=-40~85°C, C_{Bypass}=0.47uF, C_{Load}=1nF, V_{CC}=5V, unless otherwise specified.

Parameter	Symbol	Test Conditions	Min	Typ ^[1]	Max	Unit
NOMINAL PERFORMANCE						
Current-Sensing Range	I _{PR}		-100		100	A
Zero-Current Output Voltage	V _{oq}	IP=0A		0.5V _{CC}		V
VREF Output Voltage	V _{ref}	Independent of the IP input current		0.5V _{CC}		V
Differential Output Offset Voltage	V _{oq} -V _{REF}	IP=0A	-5	0	5	mV
Sensitivity	Sens	-100A<IP<100A		20* S _{coef}		mV/A
ACCURACY PERFORMANCE						
Sensitivity Error	E _{SENS}	I _P = ±100 A, T _A = 25°C		± 1		%
		I _P = ±100 A, T _A = 25~85°C		± 2.5		%
		I _P = ±100 A, T _A = -40~25°C		± 3.0		%
Offset Voltage	V _{OE}	I _P =0A, T _A = 25°C		± 15		mV
		I _P =0A, T _A = 25~85°C		± 30		mV
		I _P =0A, T _A = -40~25°C		± 25		mV
Differential Output Error	E _(V_{oq}-V_{REF})	I _P =0A, T _A = 25°C		± 20		mV
		I _P =0A, T _A = 25~85°C		± 40		mV
		I _P =0A, T _A = -40~25°C		± 30		mV
Nonlinearity	E _{LIN}	Measured using full-scale and half-scale I _P			2	%
TOTAL OUTPUT ERROR COMPONENTS: E_{TOT} = E_{SENS} + V_{OE} / (Sens × I_P)						
Total Output Error	E _{TOT}	I _P = ±100A, T _A =25°C		± 1		%
		I _P = ±100 A, T _A =25°C~85°C		± 3		%
		I _P = ±100 A, T _A = -40°C~25°C		± 3.2		%
Over Life Time drift Error	E _{olt}			±1		%

[1] The typical value is +/-1 sigma, and 68.27% of products fall within this range; The maximum/minimum value is +/-3 sigma value, and 99.73% of products fall within this range

SC840DET-100F5 Individual Performance Characteristics

Note: Over full range of TA=-40~85°C, C_{Bypass}=0.47uF, C_{Load}=1nF, V_{CC}=5V, unless otherwise specified.

Parameter	Symbol	Test Conditions	Min	Typ ^[1]	Max	Unit
NOMINAL PERFORMANCE						
Current-Sensing Range	I _{PR}		-100		100	A
Zero-Current Output Voltage	V _{oq}	IP=0A		2.5		V
VREF Output Voltage	V _{ref}	Independent of the IP input current		2.5		V
Differential Output Offset Voltage	V _{oq} -V _{REF}	IP=0A	-5	0	5	mV
Sensitivity	Sens	-100A<IP<100A		20		mV/A
ACCURACY PERFORMANCE						
Sensitivity Error	E _{SENS}	I _P = ±100 A, T _A = 25°C		± 1		%
		I _P = ±100 A, T _A = 25~85°C		± 2.5		%
		I _P = ±100 A, T _A = -40~25°C		± 3.0		%
Offset Voltage	V _{OE}	I _P =0A, T _A = 25°C		± 15		mV
		I _P =0A, T _A = 25~85°C		± 30		mV
		I _P =0A, T _A = -40~25°C		± 25		mV
Differential Output Error	E _(V_{oq}-V_{REF})	I _P =0A, T _A = 25°C		± 15		mV
		I _P =0A, T _A = 25~85°C		± 25		mV
		I _P =0A, T _A = -40~25°C		± 30		mV
Nonlinearity	E _{LIN}	Measured using full-scale and half-scale I _P			1	%
TOTAL OUTPUT ERROR COMPONENTS: E_{TOT} = E_{SENS} + V_{OE} / (Sens × I_P)						
Total Output Error	E _{TOT}	I _P = ±100A, T _A =25°C		± 1		%
		I _P = ±100 A, T _A =25°C~85°C		± 3		%
		I _P = ±100 A, T _A = -40°C ~ 25°C		± 3.2		%
Over Life Time drift Error	E _{olt}			±1		%

[1] The typical value is +/-1 sigma, and 68.27% of products fall within this range; The maximum/minimum value is +/-3 sigma value, and 99.73% of products fall within this range

SC840 series
20kA/8us overcurrent surge, High Accuracy, Current Sensor IC



SC840DET-150F5 Individual Performance Characteristics

Note: Over full range of TA=-40~85°C, C_{Bypass}=0.47uF, C_{Load}=1nF, V_{CC}=5V, unless otherwise specified.

Parameter	Symbol	Test Conditions	Min	Typ ^[1]	Max	Unit
NOMINAL PERFORMANCE						
Current-Sensing Range	I _{PR}		-150		150	A
Zero-Current Output Voltage	V _{oq}	I _P =0A		2.5		V
VREF Output Voltage	V _{ref}	Independent of the IP input current		2.5		V
Differential Output Offset Voltage	V _{oq} -V _{REF}	I _P =0A	-5	0	5	mV
Sensitivity	Sens	-150A<I _P <150A		13.333		mV/A
ACCURACY PERFORMANCE						
Sensitivity Error	E _{SENS}	I _P = ±150 A, T _A = 25°C		± 1		%
		I _P = ±150 A, T _A = 25~85°C		± 2.5		%
		I _P = ±150 A, T _A = -40~25°C		± 3.0		%
Offset Voltage	V _{OE}	I _P =0A, T _A = 25°C		± 15		mV
		I _P =0A, T _A = 25~85°C		± 30		mV
		I _P =0A, T _A = -40~25°C		± 25		mV
Differential Output Error	E _(V_{oq}-V_{REF})	I _P =0A, T _A = 25°C		± 15		mV
		I _P =0A, T _A = 25~85°C		± 25		mV
		I _P =0A, T _A = -40~25°C		± 30		mV
Nonlinearity	E _{LIN}	Measured using full-scale and half-scale I _P			1	%
TOTAL OUTPUT ERROR COMPONENTS: E_{TOT} = E_{SENS} + V_{OE} / (Sens × I_P)						
Total Output Error	E _{TOT}	I _P = ±150A, T _A =25°C		± 1		%
		I _P = ±150 A, T _A =25°C~85°C		± 3		%
		I _P = ±150 A, T _A = -40°C~25°C		± 3.2		%
Over Life Time drift Error	E _{olt}			±1		%

[1] The typical value is +/-1 sigma, and 68.27% of products fall within this range; The maximum/minimum value is +/-3 sigma value, and 99.73% of products fall within this rang

Accuracy Characteristic Curve (SC840DFT-50F5 V1)



AC & Dynamic Characteristic Curve

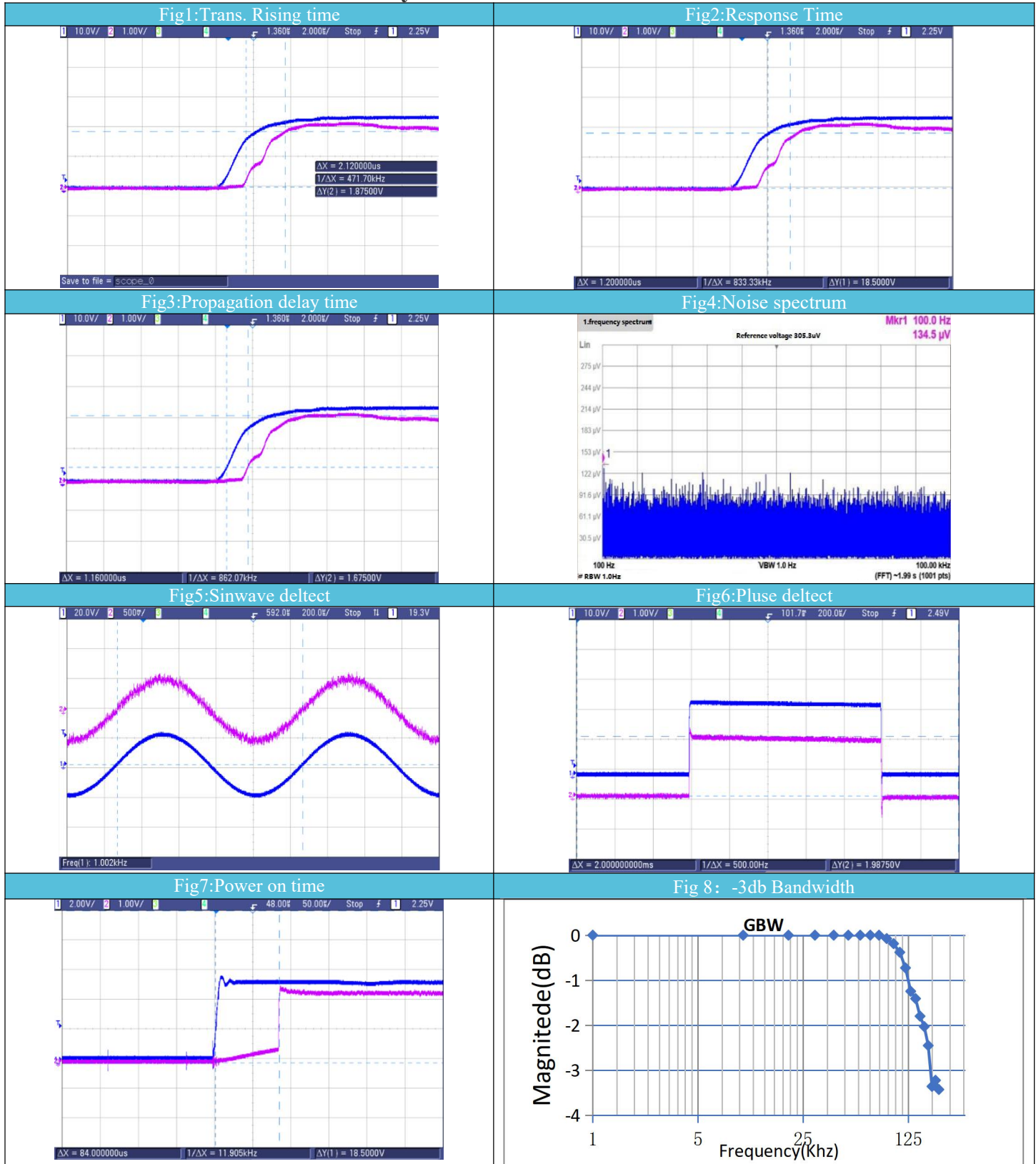

Functional Description

◆ Internal Reference Voltage

Vref is always equal to the static bias output value of VIOUT, that is, VIOUT value when IP=0A.

The relationship between VIOUT and Vref obey that following formula:

$$VIOUT = IP * Sens + Vref,$$

When SC840DFT**F5 is used, VREF constantly outputs 2.5VCC, And has a driving capacity of more than 3mA;

When SC840DFT**B5 is used, VREF constantly outputs 0.5VCC, And has a driving capacity of more than 3mA;

When SC840DFT**U5 is used, VREF constantly outputs 0.1VCC, And has a driving capacity of more than 3mA;

When SC840DFT**I5 is used, VREF is input mode, and its voltage can be modified to 0.5V-2.5V by using external input voltage. However, it is necessary to contact FAE for confirmation and inform the input voltage value along with the model to obtain the best accuracy parameters.

◆ Vfault Function

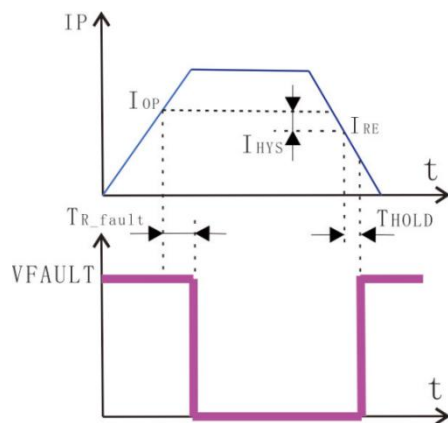

The Vfault pin can be used as an indication of overcurrent detection output after being pulled up.

When primary current exceeds IOP and after TR_fault, Vfault pin will be low;

When primary current is below IRE and after THOLD, Vfault pin will be high;

Parameter definition:

IOP:Action threshold point, for SC840, $I_{OP} = IP \times 1.3$

IRE:Recover threshold point

IHYS:Hysteresis, $I_{HYS} = |I_{OP}| - |I_{RE}|$

TR_fault:The response time of Fault . That is, the delay time from the occurrence of overcurrent to the action of Vfault pin.

THOLD:The hold time of Fault. That is, the delay time from overcurrent recovery to Vfault pin recovery.

◆ Proportional Coefficient Of Sensitivity(suitable for products with suffix B or U)

Sensitivity ratio coefficient (sens_coef), which defines the coefficient proportional to the sensitivity and VCC. The ideal coefficient is 1. If the VCC increases by 10%, the sensitivity will increase by 10%. At this time, the coefficient is 1.1, which means that the sensitivity increases by 10% compared with the ideal proportion. The relationship between the scale coefficient is described by the following equation:

$$S_{coef} = Sens_coef = SENS_{VCC} / SENS_{VCCN}$$

It is the ratio of the sensitivity SENS_VCC under the supply voltage Vcc to the sensitivity SENS_VCCN under the rated supply voltage VCCN. Through this value, we can get the sensitivity under any supply voltage.

In ideal situation:

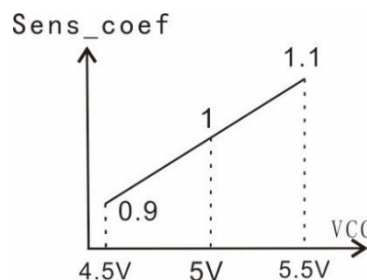

◆ Proportional Relationship

Using SC840DFT * * F5, sensitivity and zero voltage does not change with VCC proportion, including zero constant is 2.5 V. The sensitivity is 2V/IPMAX; IP_{MAX} is the measurement range value of forward current.

Using SC840DFT * * B5, sensitivity and zero voltage are changing with VCC proportion, zero for the VCC / 2, sensitivity to SENS_{VCC}* Sens_coef.

Using SC840DFT * * U5, sensitivity and zero voltage are changing with VCC proportion, zero point 0.1 VCC, sensitivity to SENS_{VCC}* Sens_coef.

Using SC840DFT * * I5, sensitivity and zero voltage does not change with VCC proportion, zero voltage is equal to VREF input voltage;

Sensitivity SENS = 2V/IP, IP is the current value in the model. Measurable current range is $[(0.5 - VREF_IN) / Sens, (4.5 - VREF_IN) / Sens]$

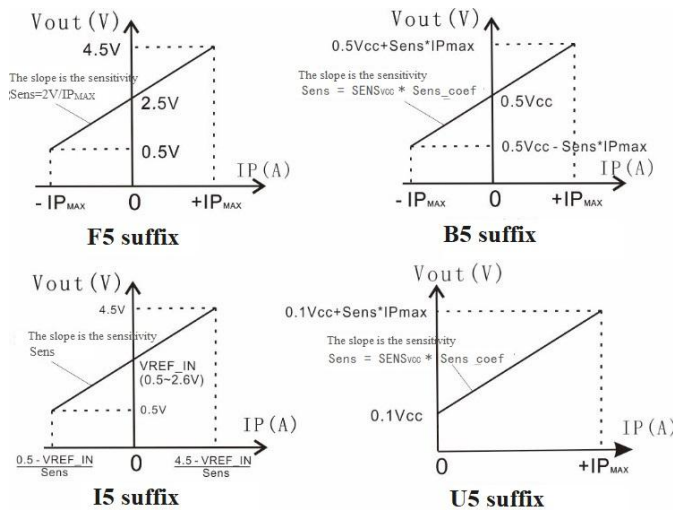

◆ Impact of External Magnetic Fields

CMFR is used to express the ability of sensor resisting impact of external magnetic fields. The larger the absolute value of CMFR, the stronger the ability to resist external magnetic interference is.

$$CMFR = 20 \lg \left| \frac{A_{CM}}{Sens/CF} \right|$$

CF is the coupling factor in G/A, multiplying by the sensitivity of the part (Sens) gives the error in mV.

For example: CMFR = -40dB, Sens = 40mV/A, CF = 10G/A, then A_{CM} is 0.04mV/G.

◆ Power Supply Rejection Ratio (suitable for products with suffix F)

Sensitivity power supply rejection ratio (PSRR_S) It refers to the sensitivity change rate (SENS_{VCC} - SENS_{VCCN}) / SENS_{VCCN} caused by the power supply change rate (VCC - VCC_N) / VCC_N. The absolute value of the ratio is 20 times of the common logarithm, the unit is dB.

$$PSRR_S = 20 \lg \left| \frac{(VCC - VCC_N) / VCC_N}{(SENS_{VCC} - SENS_{VCCN}) / SENS_{VCCN}} \right|$$

Zero current power supply rejection ratio (PSRR_Q) It refers to the zero point change VOE - VOE_N caused by the change of voltage VCC - VCC_N. The absolute value of the ratio is 20 times of the common logarithm, the unit is dB.

$$PSRR_Q = 20 \lg \left| \frac{VCC - VCC_N}{VOE - VOE_N} \right|$$

◆ **Delay time t_{pd} and Response time $t_{response}$**

Both delay time and response time are used to characterize the time difference between primary side and secondary side;
 The delay time is the time difference when the secondary output reaches 20% of the steady-state output value and the primary output reaches 20% of the steady-state current;
 The response time is the time difference when the secondary output reaches 90% of the steady-state output value and the primary output reaches 90% of the steady-state current.

Rise Time t_r

The rising time is used to represent the time difference of the secondary side itself, that is, the time difference between the time when the output of the secondary side reaches 90% of the steady-state output value and 10% of the steady-state output value.

Power-On Time t_{po}

Power-On Time is defined as the time it takes for the output voltage to settle within $\pm 10\%$ of its steady-state value under an applied magnetic field, after the power supply has reached its minimum specified operating voltage.

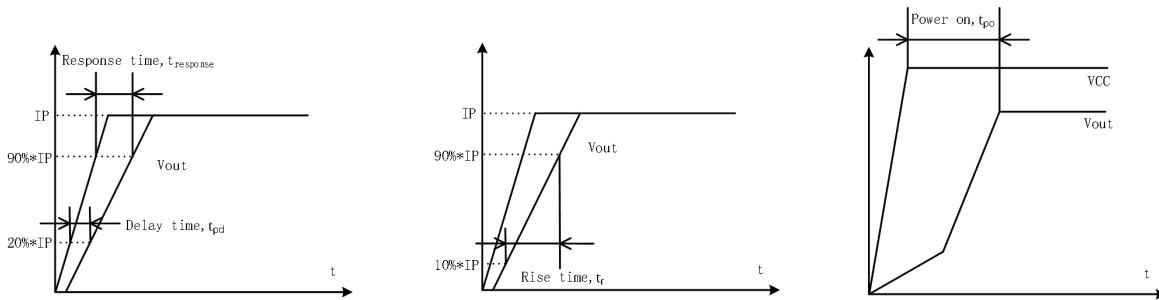

◆ **Thermal resistance $R_{\theta JA}$**

Based on a demo board, the thermal resistance is calculated by measuring the chip top temperature and power value. According to the thermal resistance, the junction temperature can be calculated as a reference. The actual surface temperature measurement value is shown in the relationship between the package temperature and the measured current.

$$T_J = T_A + (R_{\theta JA} * POWER) = T_A + (R_{\theta JA} * IP^2 * R_{PRIMARY});$$

Where T_J is junction temperature and T_A is ambient temperature.

◆ **Typical Application**

When SC840DFT**F5/B5/U5 is used, VREF is in output mode, which can be connected to other circuits or suspended.

1. Schematic diagram of connection between SC840 and ADC:

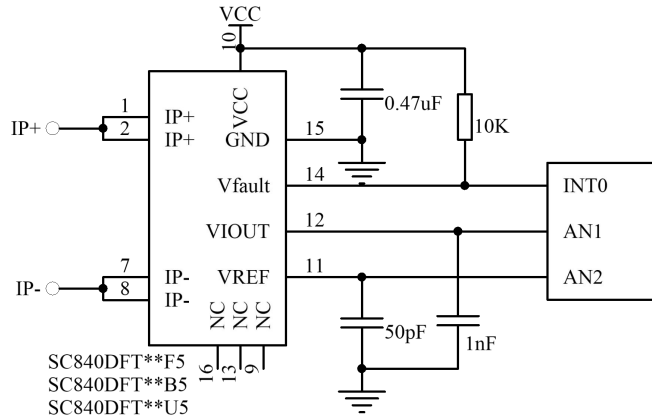

2. Schematic diagram of connection between SC840 and ADC:

$$VOUT = IP * Sensitivity * (5R / R)$$

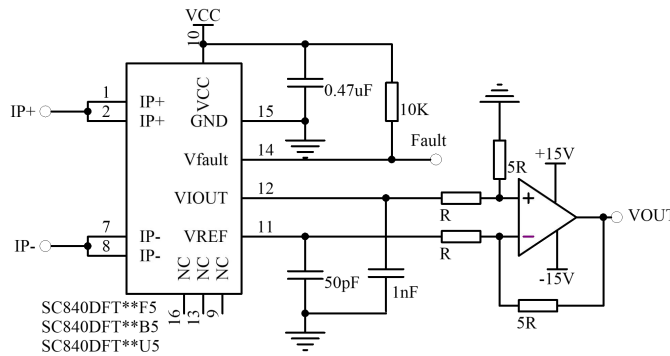

3. When SC840DFT**I5 is used, VREF is the input mode, and the external input voltage can be used to 0.5V-2.5V. At this time, the static output voltage of VOUT (i.e. under zero current input) is also modified to the same voltage as VREF.

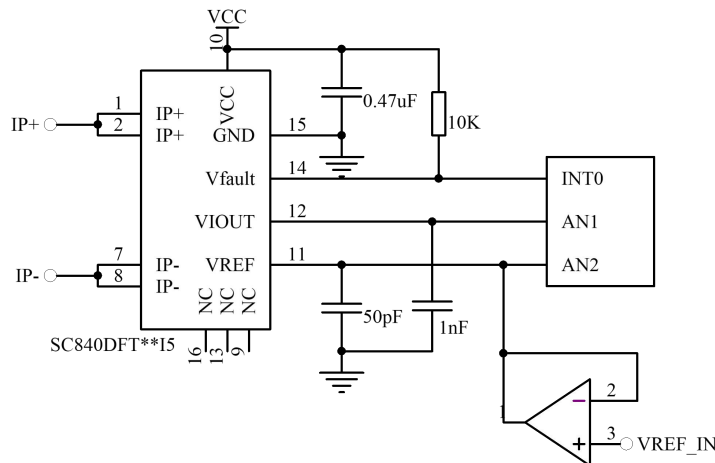

SC840 Evaluation Board Layout

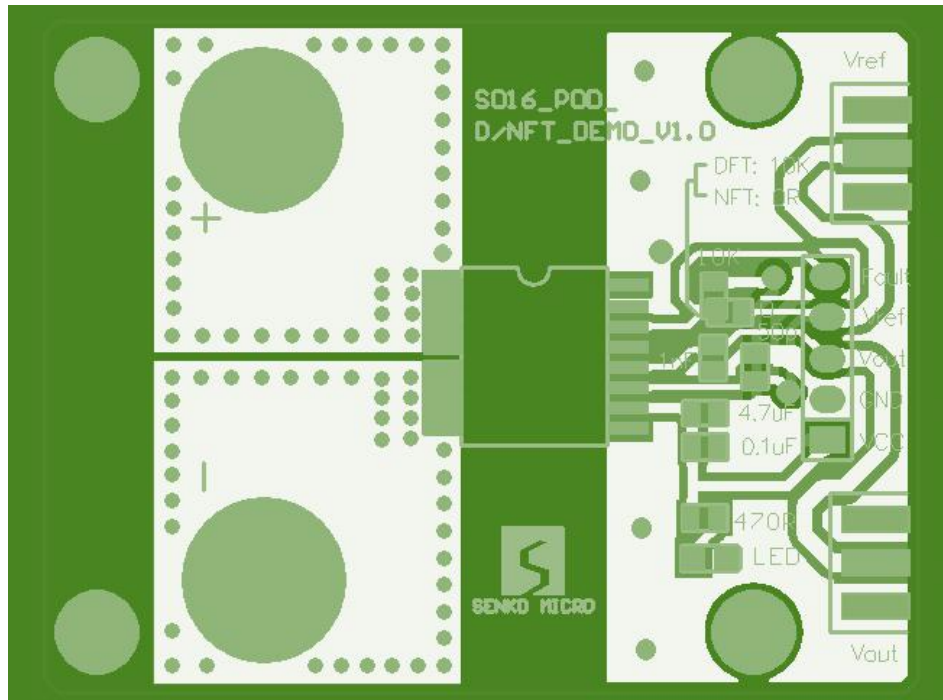

Mark Description

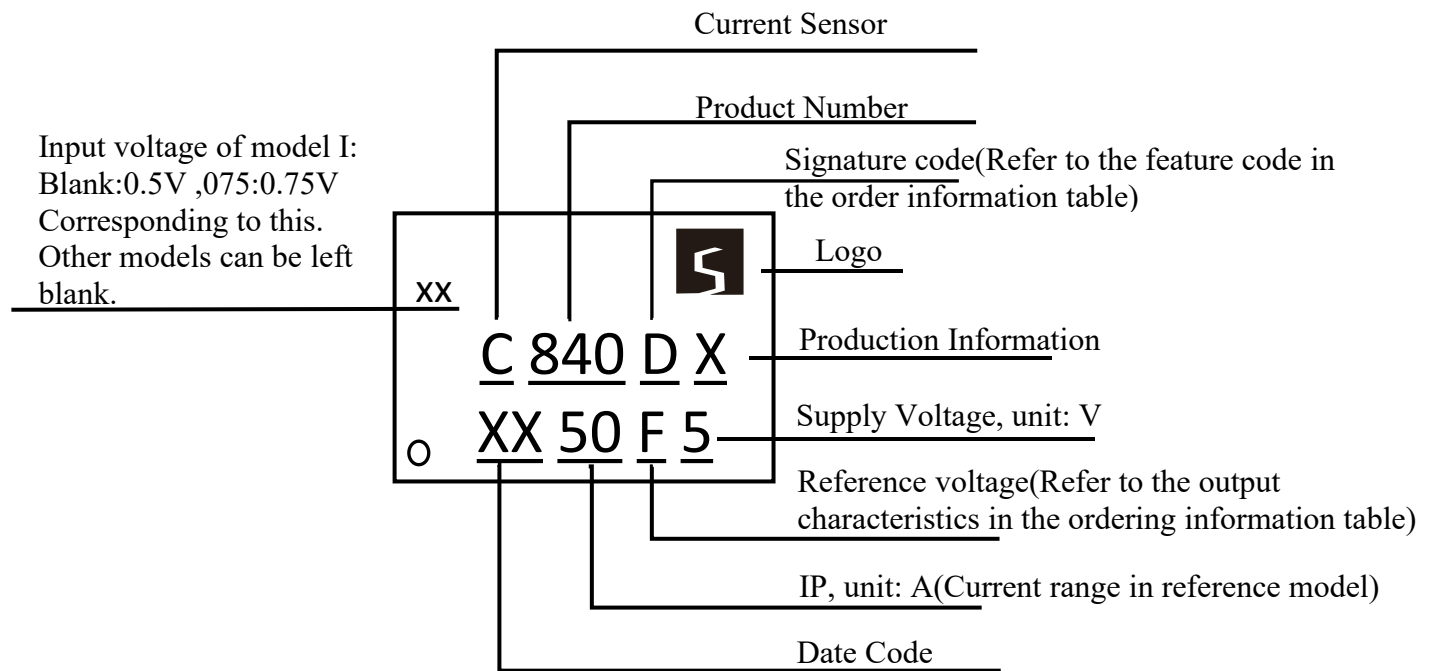

Note:X is non fixed character, defined by Senko Micro naming rules

Package Information

Note: Package is SOP-16SW, all dimensions are in millimeters.

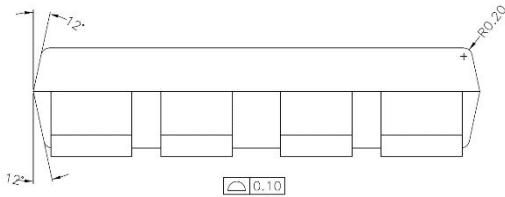
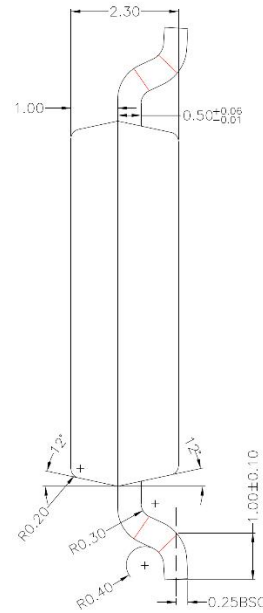
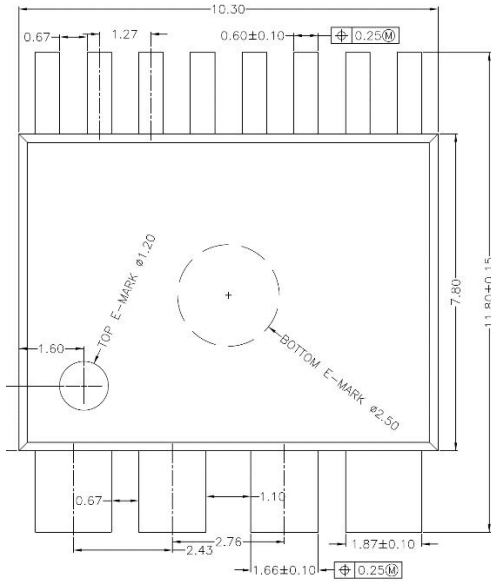

NOTES:

- 1.GENERAL TOLERANCE: LINEAR ±0.05, ANGULAR ±1°, RADIUS ±0.05.
- 2.PKG SURFACE Ra=0.60~1.0um EXCEPT SLEEK AREAS.
- 3.EJECTION & INDEX PIN MARK DEPTH 0.20±0.10.
- 4.GENERAL CORNER RADIUS R0.20.
- 5.MAX RESIN GATE PROTRUSION 0.25MAX.
- 6.ALL DIMENSIONS IN MILLIMETERS.

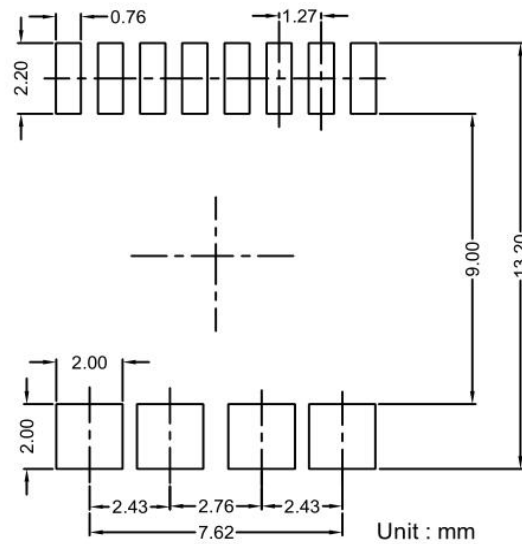

PCB Layout Reference View

SC840 series

20kA/8us overcurrent surge, High Accuracy, Current Sensor IC



Important Notice

SENKO micro-electronics co., Ltd. Reserves the right to make, from time to time, such departures from the detail specifications as may be required to permit improvements in the performance, reliability, or manufacturability of its products. Before placing an order, the user is cautioned to verify that the information being relied upon is current.

SENKO micro's products are not to be used in life support devices or systems, if a failure of an SENKO micro. product can reasonably be expected to cause the failure of that life support device or system, or to affect the safety or effectiveness of that device or system.

The information included herein is believed to be accurate and reliable. However, SENKO micro-electronics co., Ltd. assumes no responsibility for its use; nor for any infringement of patents or other rights of third parties which may result from its use.

For the latest version of this document, visit our website: www.senkomicro.com

Revision History

Revision	Change	Page	Author	Date
1.0	Initial draft		Jon	2019.09
1.1	Released to AE/TE/PE/FAE review		Jon	2019.12
1.2	Double check for all review		All	2020.01
1.3	Release to customer for sample		Jon	2020.02
1.4	Add order info. In page2		Jon	2020.02
1.5	Modify the application circuit diagram and noise spectrum diagram		Tom	2020.2
1.6	Update the mark information of page17 from 050 to 50/x-g.		Jon	2020.03
1.7	Correct the batch accuracy data to TBD		Jon	2020.03
1.8	Fixed model code on page2		Jon	2020.07
1.9	Modify the tape to 1000pcs		Mei	2020.10
2.0	Add 30I5 model and modify the new block diagram		Mei	2021.1
2.1	Replace Exterior View		HY	2021.3
2.2	Add SC840DET-150F5		Emma	2021.03
2.3	Update typical parameters		Mei	2021.03
2.4	Update typical parameters		Mei	2021.03
2.5	Add UL,supplement the I description of VREF input mode	1,2,18	Jon	2021.04
2.6	Update 75I5 precision data		Emma	2021.12
2.7	Modify part of the data and description		Emma	2022.02